

Enrollment No: _____ Exam Seat No: _____

C.U.SHAH UNIVERSITY
Winter Examination-2018

Subject Name : Basics of Civil & Structural Engineering

Subject Code : 4TE02BCS1

Branch: B.Tech (All)

Semester : 2

Date : 02/11/2018

Time : 02:30 To 05:30

Marks : 70

Instructions:

- (1) Use of Programmable calculator & any other electronic instrument is prohibited.
 - (2) Instructions written on main answer book are strictly to be obeyed.
 - (3) Draw neat diagrams and figures (if necessary) at right places.
 - (4) Assume suitable data if needed.
-

Q-1 Attempt the following questions: (14)

- a) Mention the fundamental principles of Surveying.
- b) Define levelling.
- c) Draw a neat sketch of a Plumb-Bob.
- d) Enlist the various types of compass.
- e) What are the ingredients of concrete?
- f) Write the various uses of bricks.
- g) Definition of remote sensing.
- h) Define kinematics.
- i) What is perpendicular axis theorem?
- j) What are the different types of truss?
- k) State the Lami's Theorem.
- l) Define concurrent forces.
- m) What is principle of transmissibility?
- n) State Triangle law of forces.

Attempt any four questions from Q-2 to Q-8

Q-2 Attempt all questions



- (a) Explain the two methods of ranging with a neat sketch. (04)
- (b) Discuss the classification of survey based on instruments, methods, purposes and nature of field. (10)

Q-3 Attempt all questions

- (a) Define contours & its uses? Discuss the characteristics with the help of neat sketches. (04)
- (b) Explain the various classification of direct leveling with neat sketches. (10)

Q-4 Attempt all questions

- (a) Explain various types of lime. (06)
- (b) Explain the various types of cement used for construction. (04)
- (c) Write short notes on metals with its uses and properties. (04)

Q-5 Attempt all questions

- (a) Explain briefly the requirements of stone suitable for construction. Enlist the types of stones with its uses. (06)
- (b) What are the uses and application of GPS? (04)
- (c) Write short notes on the importance of sand and aggregate in construction. (04)

Q-6 Attempt all questions

- (a) A T-shaped bracket supports the four loads shown in Figure.1. Determine the reactions at A and B (a) if $a = 10$ m ; (b) $a = 7$ m. (08)
- (b) Determine magnitude and resultant force of the force system shown in figure.2. (06)

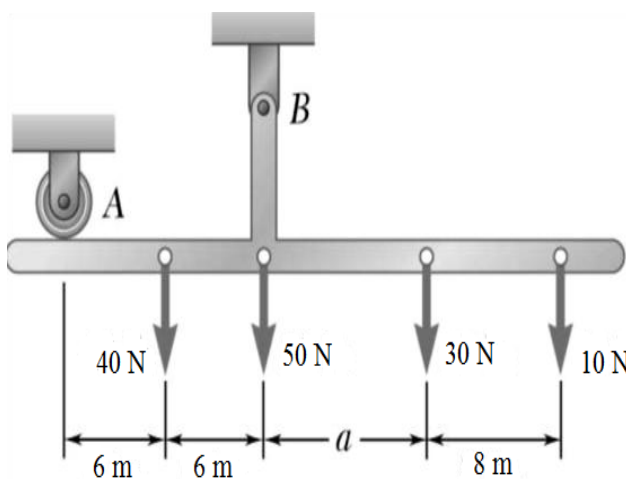

Figure.1.

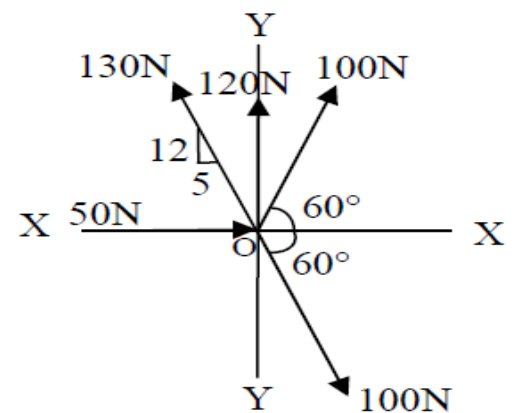

Figure.2.



Q-7

Attempt all questions

(a) Determine the forces in all the members of the truss shown in Figure.3.

(14)

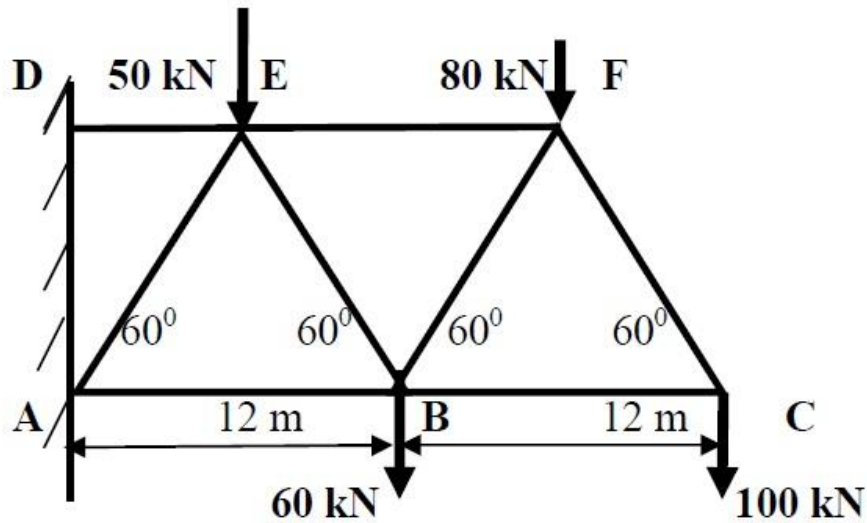

Figure.3.

Q-8

Attempt all questions

(a) Find the centroid of a section shown in the figure.4.

(04)

(b) Determine the I_{yy} of section shown in Figure.5.

(10)

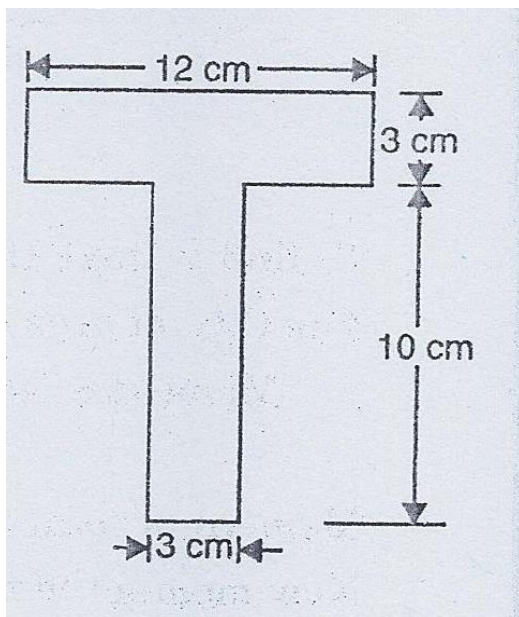

Figure.4.

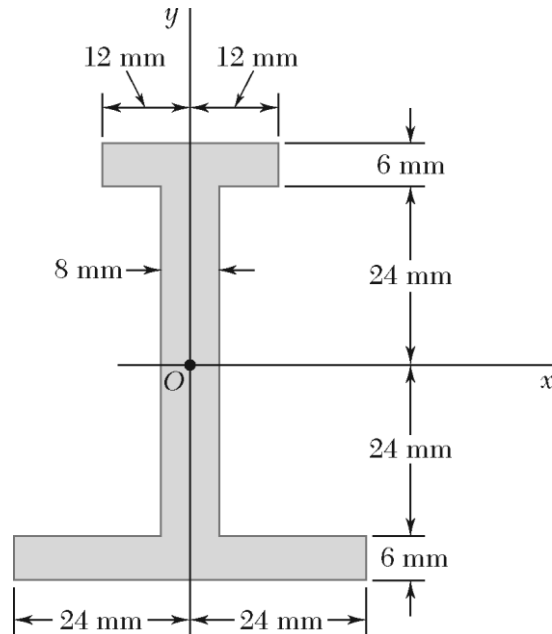

Figure.5.